

Control unit

Type 8516 for 230 V AC and 110 V DC drives

8516



Control unit Type 8516 for 230 V AC and 110 V DC drives

Description

The type 8516 control unit offers the option of interlocking the manual level in addition to the usual options provided by the types 8512 / 8513 / 8514 control units. A built-in relay to monitor the control voltage = remote operation voltage is provided at terminals 15 and 16. Only when this relay drops out, e.g., by a failure of the remote operation voltage or an external switching function (key switch, etc.) is the manual level activated. This applies both to the command button built in to the control unit and to the external command encoder (terminals 5, 6, 7).

The pulse lengthening (locking time) can be set from the outside (potentiometer at the front / back).

The type 8516 control unit is connected directly to the supply / motor voltage of the drive / switch, etc. The motor voltage and the motor current are available at terminals 3 (On) and 4 (Off) for the period of the set pulse lengthening time (AC up to max. 5 A, DC, see the diagram).

Since the switching principles for various application cases, limit switch motor versions and required switching capacity.

The switch position reporting is done via separate limit switches in the drive so that position reporting is also done while commands are being given (motor running). The drive position is displayed in the control unit by means of LEDs, whose colour should be specified when ordering.

The respective zero-potential contacts are available for further reporting. The action direction (make/break) of the position reporting switches can be set at the factory. The standard setting is »Make«. Other settings must be specified when ordering. Any desired message display can be produced by switching both the input connections and the output contacts K1, K2. The transmission of messages from the drive to the control unit is virtually independent of the length of the cable or any capacitive effects.

Switch panel installation:

The type 8516 control unit is also available as a switch panel version (for example, for installation in a door).

The relevant device connections are at the back of the unit. The controls and LEDs are under a cover at the front of the unit.

Dimensions switch panel housing:

WxHxD approx. 144x96x125 mm

Dimensions front cover:

WxHxD approx. 144x96x32 mm

Dimensions door cutout:

WxH 138+1.0 x 92+0.8 mm

Further details on request.



Technical data

Dimensions	WxHxD 100x70x115 mm
Housing material	ABS / polystyrene
Installation	Top hat rail in accordance with DIN EN 50022
IP type of protection	Housing: IP 40; connections IP: 20
Ambient temperature	-20°C to +70°C (rel. humidity 5-95%)
Connections:	
Control buttons optional	2x »ON« / »OFF« installed externally via terminal connections
Interlocking	via external switches and built-in control voltage monitoring
Pulse lengthening	3 s to 10 s can be set
Motor voltage	230 V AC max. 5 A motor current 110 V DC max 0.5A loading of the internal relay contacts
Remote operation connection	with relay coil approx. 250 mW DC 24 V, 60 V, 110 V
Messages:	
Display	2 LEDs, colours red, yellow, green, blue, according to the order Standard: ON »red«; OFF »yellow«
Contacts	a zero-potential contact for the »ON« / »OFF« messages respectively Standard: »Make-type«; optionally »Break-type«
Loading	U ≤ AC 250 V; I ≤ 2 A; P ≤ 500 VA U ≤ DC 110 V; I ≤ 0.3A; P ≤ 50 W
Electric strength	Field side / reporting contacts / remote control current / drive current respectively for 1 minute: 4 kV _{eff.}

Ordering information

Standard housing	Part No.
Motor 230 V AC, remote operation current 24 V DC	310260
Motor 110 V DC, remote operation current 24 V DC	310265
Motor 110 V DC, remote operation current 110 V DC	310267
Switch panel housing:	
Motor 230 V AC, remote operation current 24 V DC	310270
Motor 110 V DC, remote operation current 24 V DC	310275
Motor 110 V DC, remote operation current 110 V DC	310277

Changes can be made at any time due to mistakes or as the result of technical progress. All rights reserved.

8516

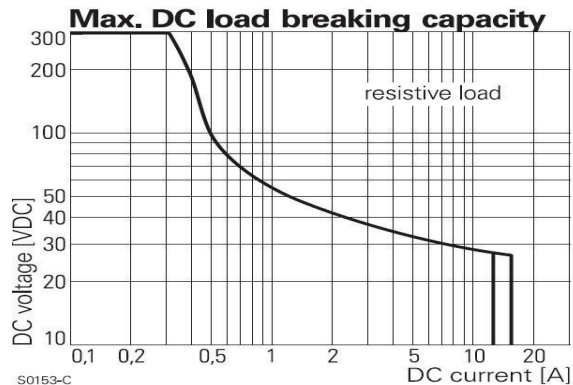
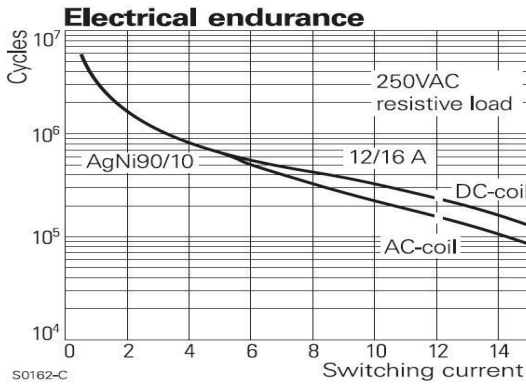
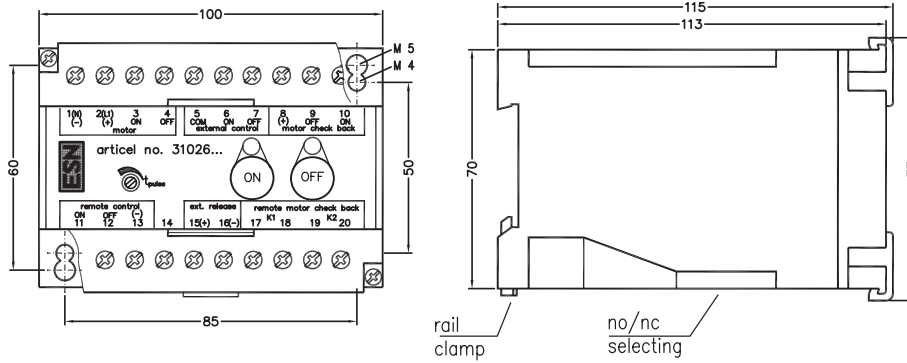

Wiring

Principal drawings of different AC/DC motors connected to Motor-Control-Unit (only one at one time)

Motor with different coils with position switches connected in series. Motor-current < contact power switching capability

Motor with different coils without position switches connected in series. Motor-current = contact power switching capability

Drive with reversing contactor circuit. Motor-current = power switching capability of internal contacts

