

PT100 thermosensor

Type 8434 2-wire and 3-wire cable connection

8434 ESN

PT100 thermosensor Type 8434 2-wire and 3-wire cable connection

Description

These thermostats (temperature sensors) or the 8434 series are especially suitable for applications that place high requirements concerning switching accuracy and reproducibility.

The robust construction permits reliable use at the rail as a precision thermostat for points heater controllers. The compact construction allows use for switch cabinet heaters or as an overtemperature detector.

The temperature sensor is usable in two different electrical versions, a two-wire version for short distances between sensor and PT100-amplifier and a three-wire version for longer distances or higher precision of measurement.

A fastening adapter, the type 913001, is available on request as an accessory for installation at the foot of the rail.

The new type of electrical quick-connection technology allows simple inventory without needing to worry about various cable lengths.

Function

The heart of the sensor is the temperature sensitive PT100 resistor.

This type of sensor is an analog sensor where the resistance value is a function of the current ambient temperature. To use this sensor you need a special amplifier that supply the sensor and give you different output signals. We offer such an equipment under part no. 420500/420501

Installation notes

see data sheet "QUICKON"!

See the complete brochure folder for additional temperature monitors, evaluation equipment and accessories.



Technical data

Dimensions	Ø 27 mm, L approx. 155 mm; see figure
Housing	Stainless steel / PA; protection type: IP 67
El. connection	Quick-connection system
Wire cross-section	1 to 1.5 mm ² (strands Ø 0.2 mm)
Wire insulation	PVC or PE is permissible
Wire external diameter	
Three-wire cable	permitted 5.6 - 8.5 mm (PG 13.5)
Ambient temperature	-30°C to +100°C
Switching point temperature	-30°C to +100°C
Hysteresis	none
Note	The switching point temperature and the hysteresis are depending from the amplifier you use
Measuring error	max.: ±0.5°C
Function:	PT100 resistor platin resistor with 100 ohmic resistance at 0°C
Accessories:	
Rail attachment adapter	Type 913001, part No. 110404
Amplifier	part no. 420500, 420501

Ordering information

Type	Part No.
8434 PT100	110500

Variant type 8434 Art. No. 110500 (stainless steel 1.4305)

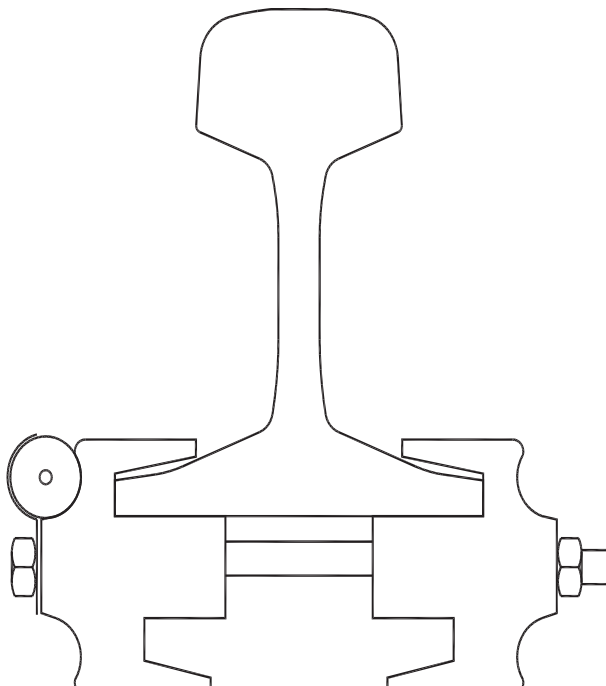
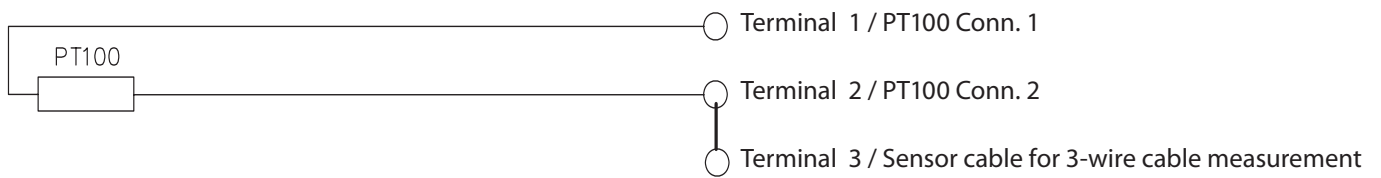
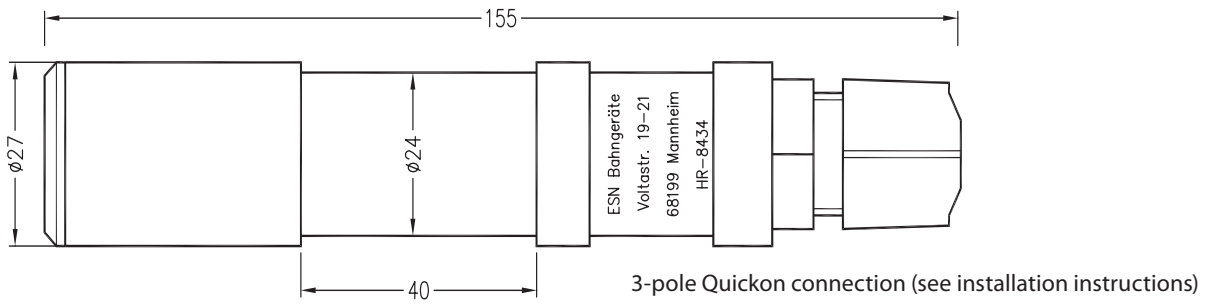

Rail Mounting Fixture, part no. 110404